

RF Troubleshooting

Abbreviations in fault finding charts

BB	Base band
DCS/PCN	GSM1800
PCS	GSM1900
EGSM	Extended GSM900
ESD	Electro Static Discharge
GPRS	General Packed Radio Service
HSCSD	High Speed Circuit Switched Data
LO	Local Oscillator
PA	Power Amplifier
PWB	Printed Wired Board
PLL	Phase Locked Loop
RF	Radio Frequency
RX	Receiver
SA	Spectrum analyzer
TX	Transmitter
UHF	Ultra High Frequency
VCO	Voltage controlled oscillator
VHF	Very High Frequency

Introduction

Two types of measurements have to be done for repair of the phone boards:

- RF measurements shall be done using a Spectrum Analyzer together with a high-frequency probe. (Note, that signal will be significantly attenuated). Correct attenuation can be checked by using a "good" phone board, for example.
- LF (Low frequency) and DC measurements shall be done with a an oscilloscope together with an 10:1 probe.

Always make sure that the measurement set-up is calibrated when measuring RF parameters at the RF connector. Remember to include the correct losses in the module repair jig and the connecting cable when realigning the phone.

Most RF semiconductors are static discharge sensitive. ESD protection must be taken into account during repair (ground straps and ESD soldering irons).

Mjoelner RF ASIC is moisture sensitive. Therefore, Mjoelner RF ASIC must be pre-baked prior to soldering.

Reference number	Name	Reference number	Name
N601	Mjoelner RF ASIC	X602	RF Connector
B601	26 MHz Xtal	L801	Directional Coupler
Z602	GSM1800 RX SAW	V801	Detector Diode
Z603	GSM1900 RX SAW	Z601	Antenna switch
Z604	EGSM RX SAW filter	N801	Power Amplifier
Z701	EGSM TX SAW filter		
T701	GSM1800/GSM1900 TX Balun		
V802	EGSM Pre-amplifier		
G701	3.7 GHz VCO		
T702	VCO Balun		
X600	Antenna signal clip		
X601	Antenna ground clip		

RF Measurement points

RF Supply points

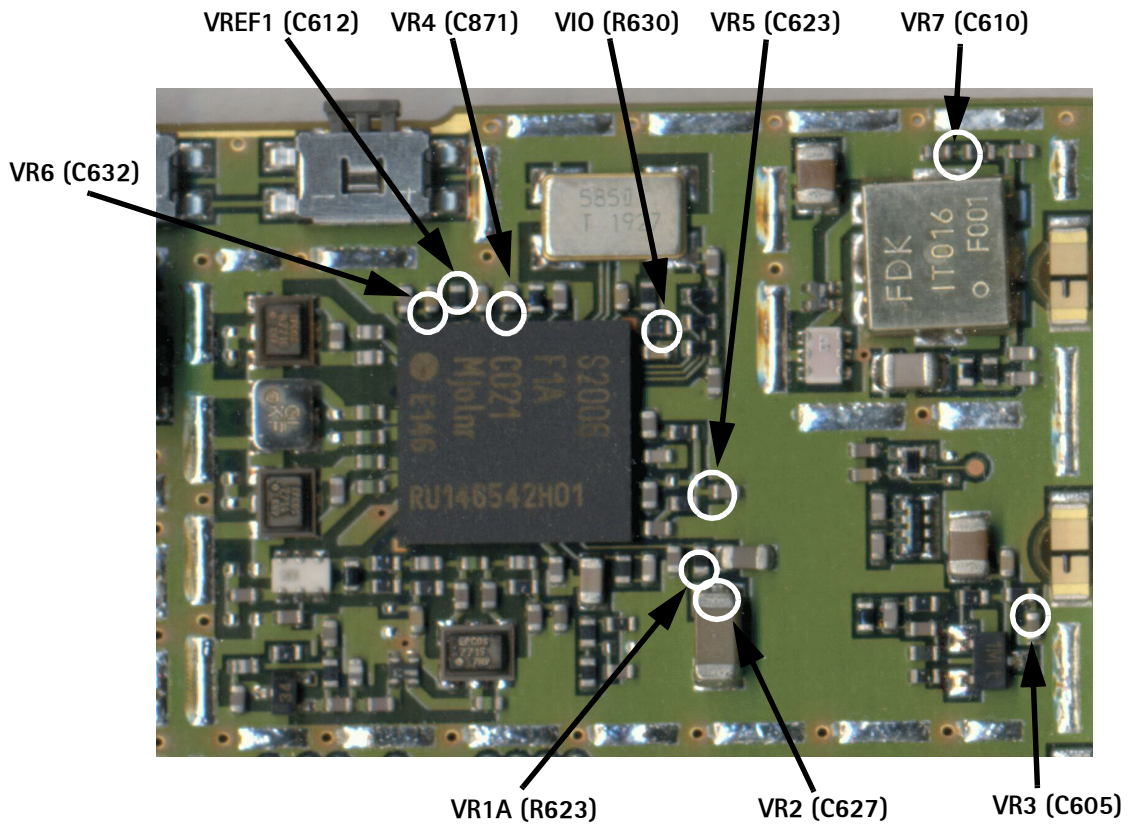

Figure 2: RF Supply points inside Mjoelner can

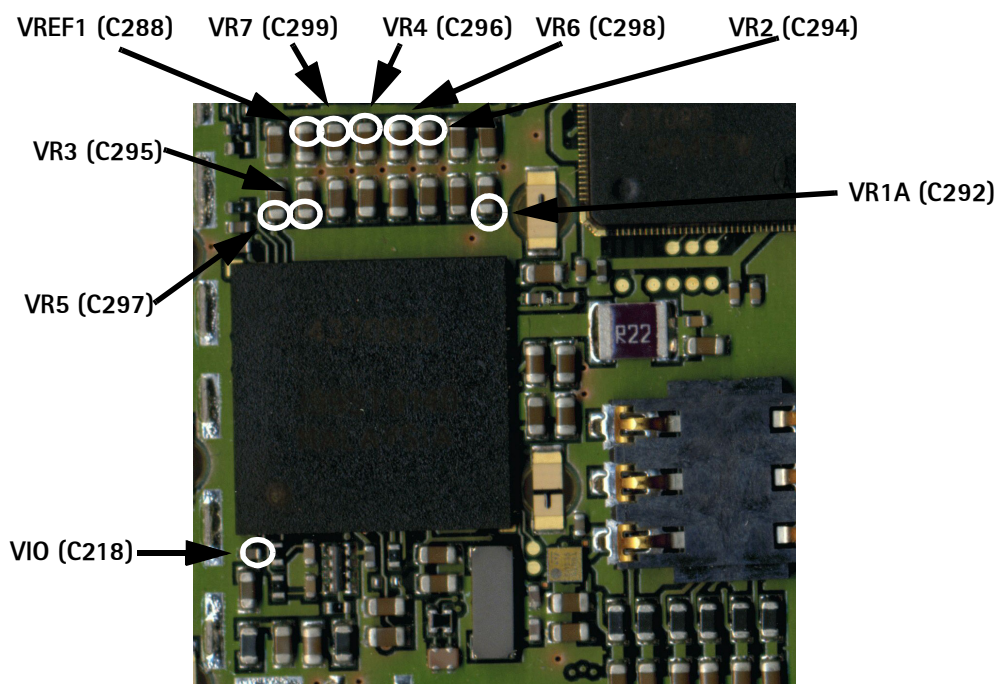

Figure 3: RF Supply points inside BB can

RF power supplies are generated in the UEM and can be measured either in the Mjoelner can or in the baseband can. Circles mark the measurement points inside the pictures.

Measurement of VR7 inside Mjoelner can requires removal of RF shielding frame. Therefore, VR7 shall be measured inside baseband can

Measurement points in the receiver

Measurement points are shown circled on the picture below.

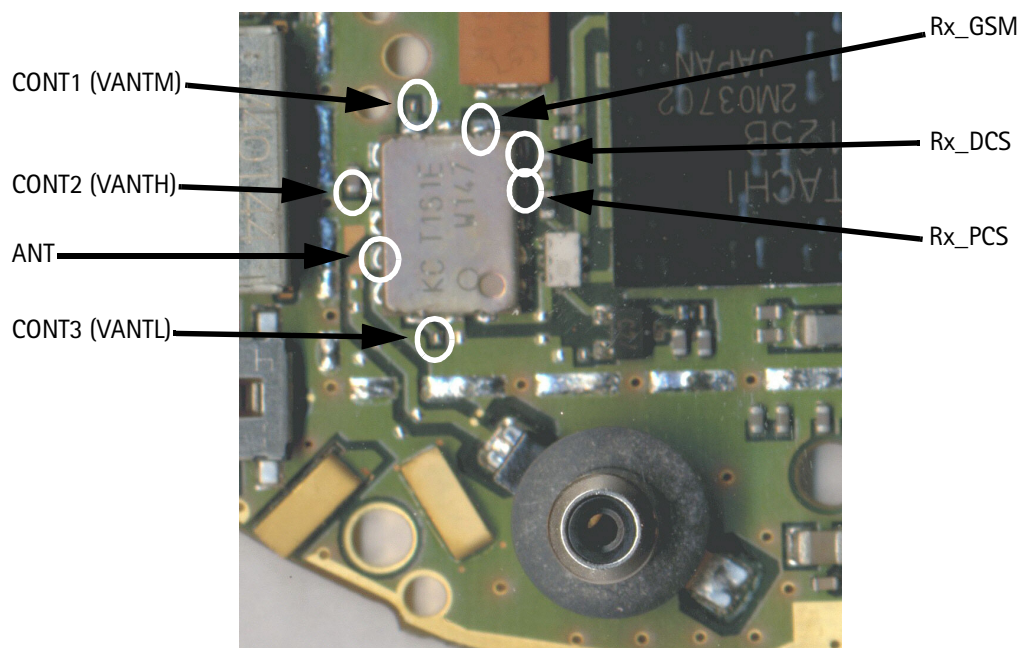

Figure 4: Rx measurement points at antenna switch module

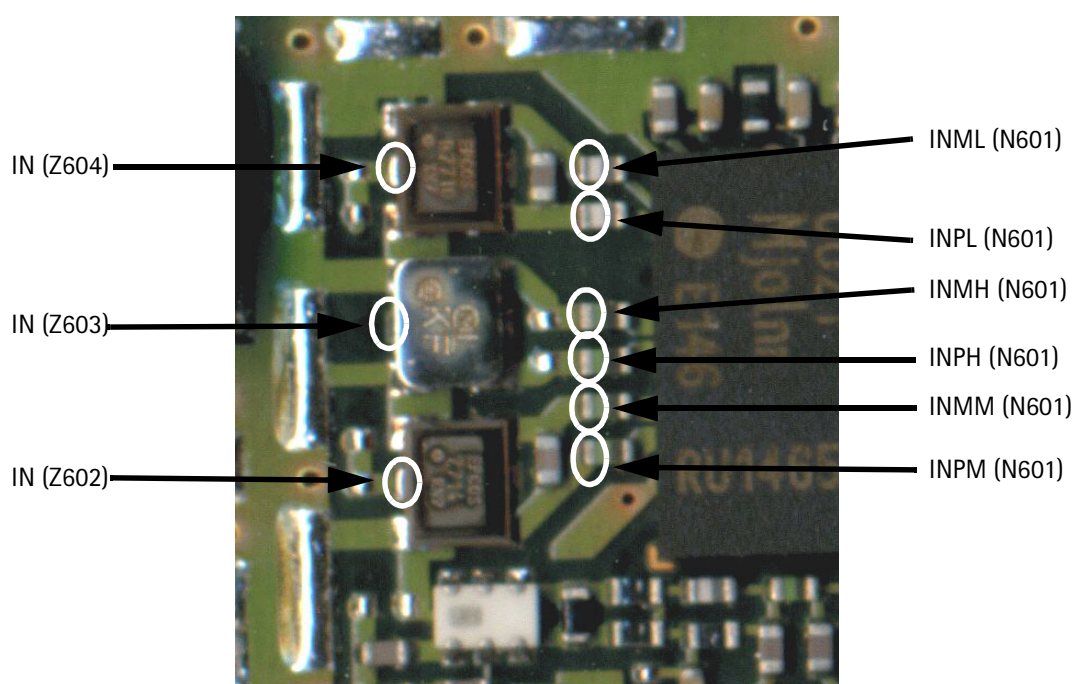

Figure 5: Rx measurement points at Rx SAW filters and Mjoelner RF ASIC

There are no specific test points to measure RX I/Q signals. If necessary, RXIINN and RXQINN signals can be measured by removing the solder resist on top of shown vias. In following pictures.

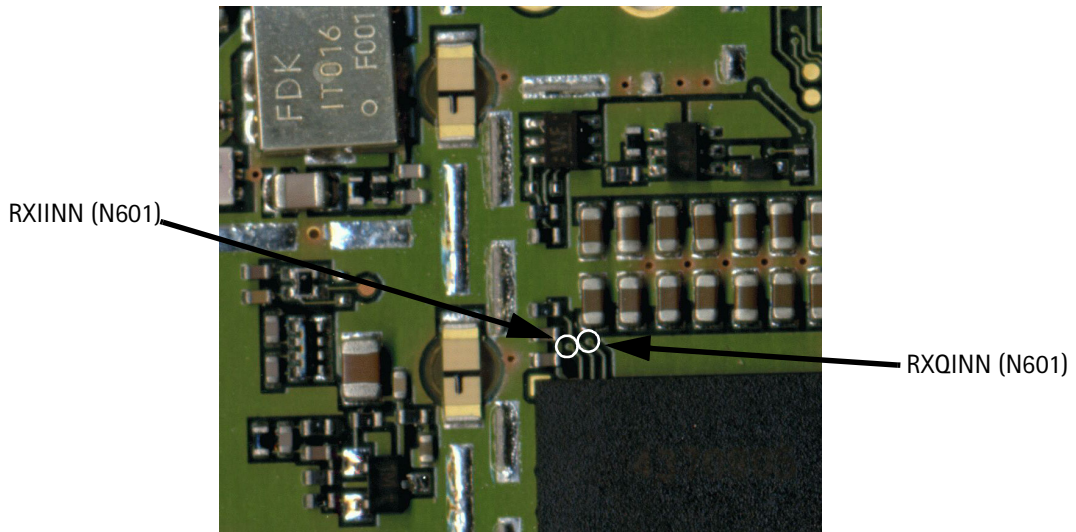

Figure 6: Rx measurement points inside BB can (RXIINN, RXQINN)

Measurement points in the transmitter

Measurement points are shown in the picture below,

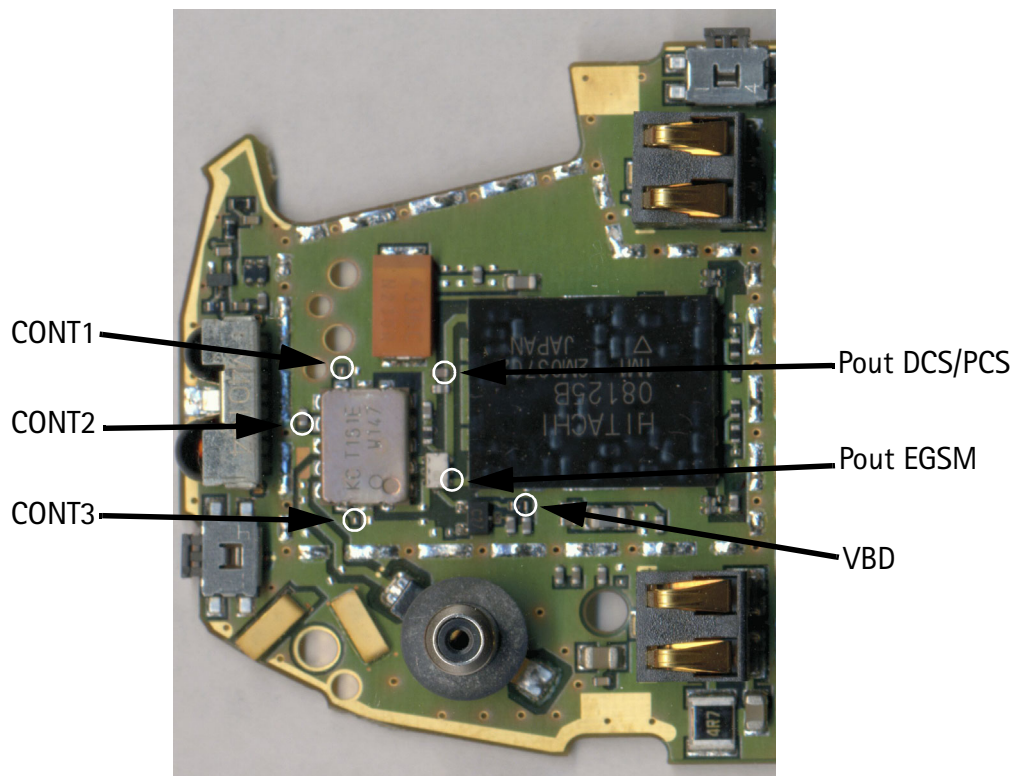

Figure 7: Tx measurement points inside PA can

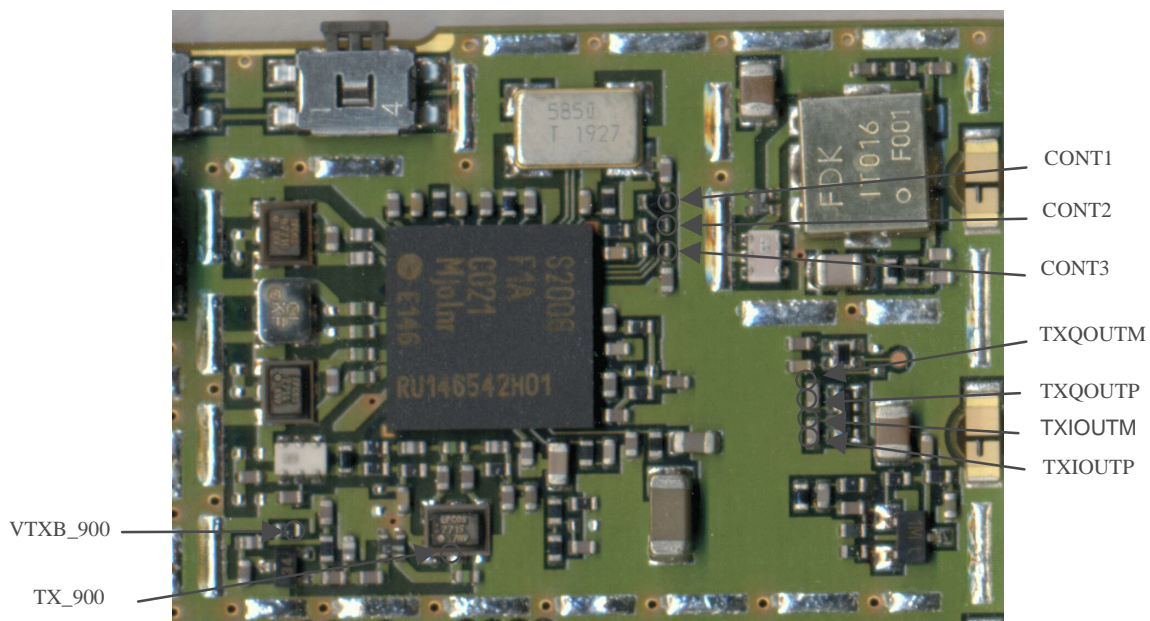

Figure 8: Tx measurement points inside Mjoelner can

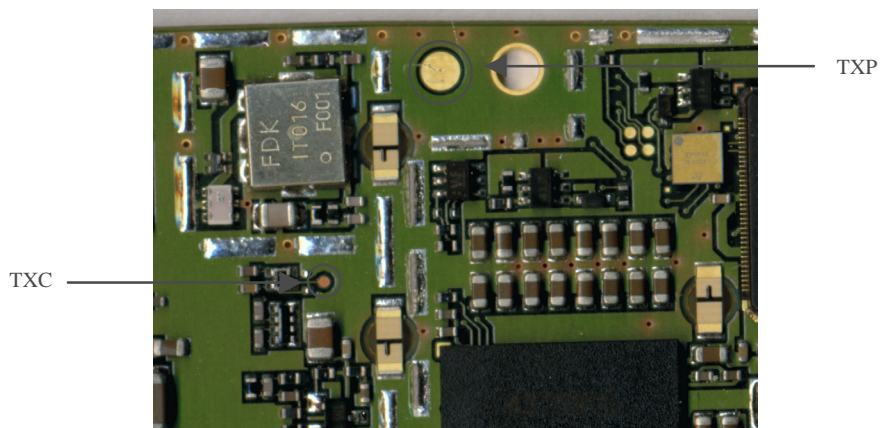

Figure 9: TX measurement points for TXC, TXP signals

RF in general

The RF part is a triple-band direct conversion transceiver. Using direct conversion no intermediate frequencies are used for up- or down- conversion.

The VCO is set to either twice or four times (depending on the band used) the wanted RX or TX frequency. The VCO frequency is divided by either 2 or 4 and fed to the mixers (down-conversion) or modulators (up-conversion). Up- or down- conversion is done in one step, directly between RF frequency and DC. All up and down-conversion takes place in the RF ASIC named Mjoelner (N601).

Mjoelner RF ASIC also contains PLL and LNAs for all used bands. A DC control section is included in to power and/or control EGSM TX buffer, detector and antenna switch. The Mjoelner RF ASIC is controlled via a serial bus.

Mjoelner RF ASIC contains an integrated VCXO which uses an external 26 MHz Xtal. No analogue AFC signal is needed. AFC is done via the serial interface of Mjoelner.

The interface between Mjoelner RF ASIC, UPP and Bluetooth uses a 26 MHz reference clock. An external 26 MHz reference clock buffer is used to drive Bluetooth module.

The RF supports HSCSD (High Speed Circuit Switched Data) and GPRS (General Packed Radio Service), meaning multi-slot operation, this will not require special equipment or procedures in repair situations.

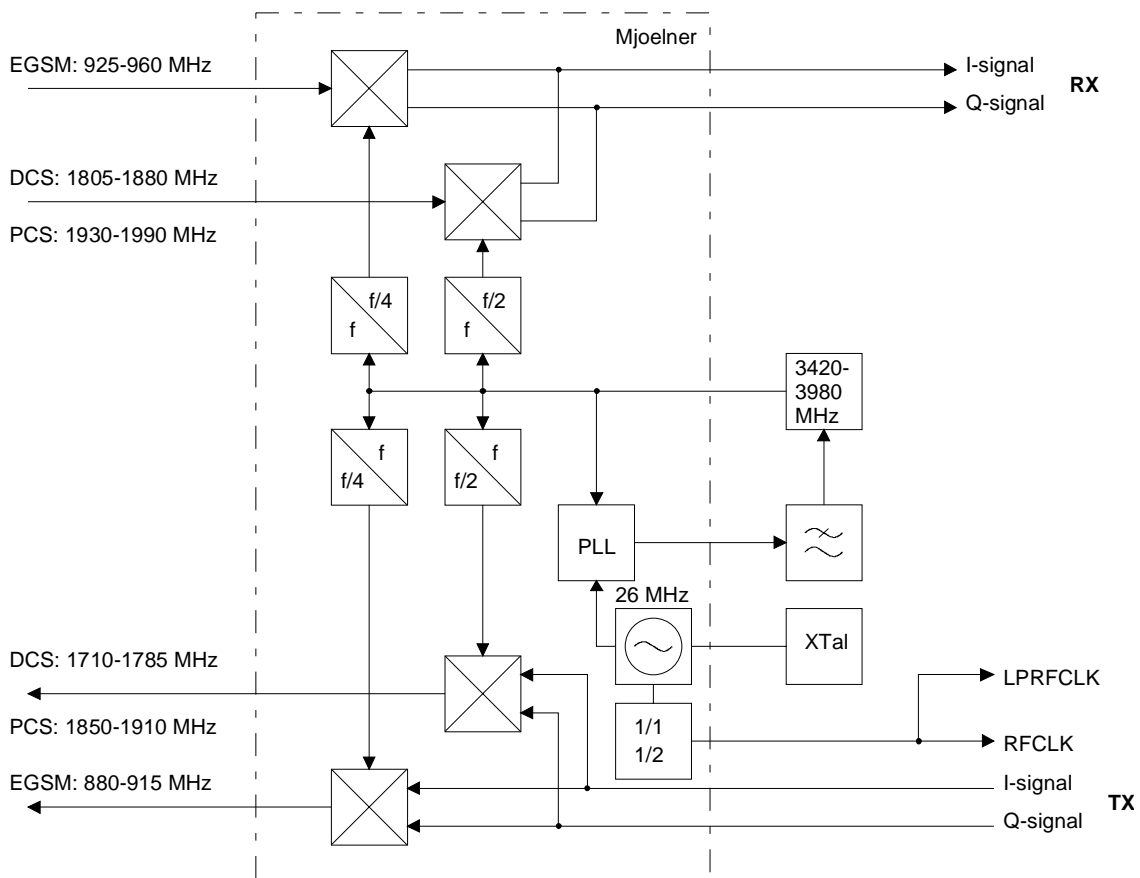

Figure 10: RF frequency plan

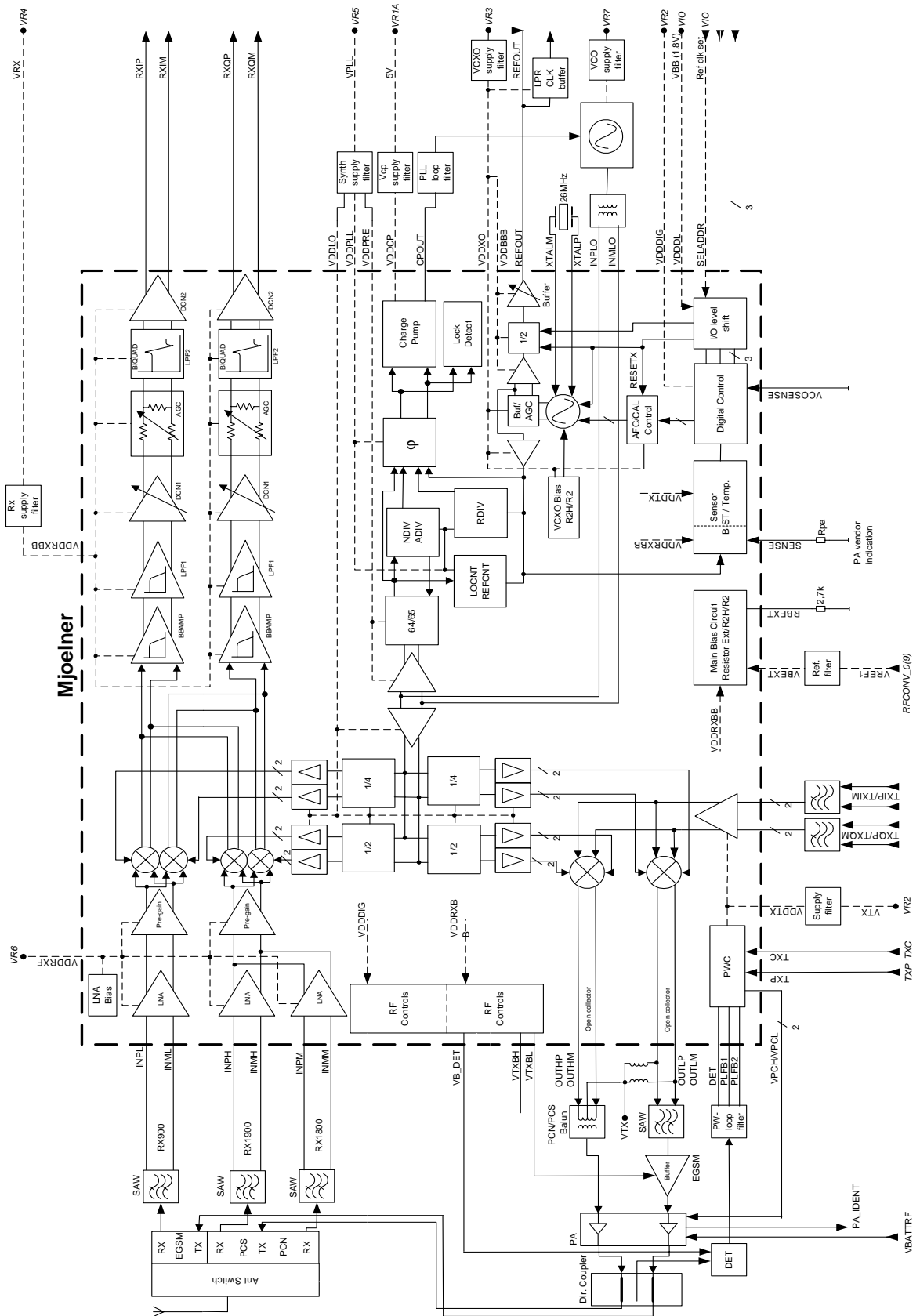

Figure 11: RF Block diagram

RF Power Supply Configuration

All power supplies for the RF Unit are generated in the UEM IC (D200). All RF supplies can be checked either in Mjoelner can or in BB can.

The power supply configuration used is shown in the block diagram below. Values of voltages are given as nominal outputs of UEM. Currents are typical values.

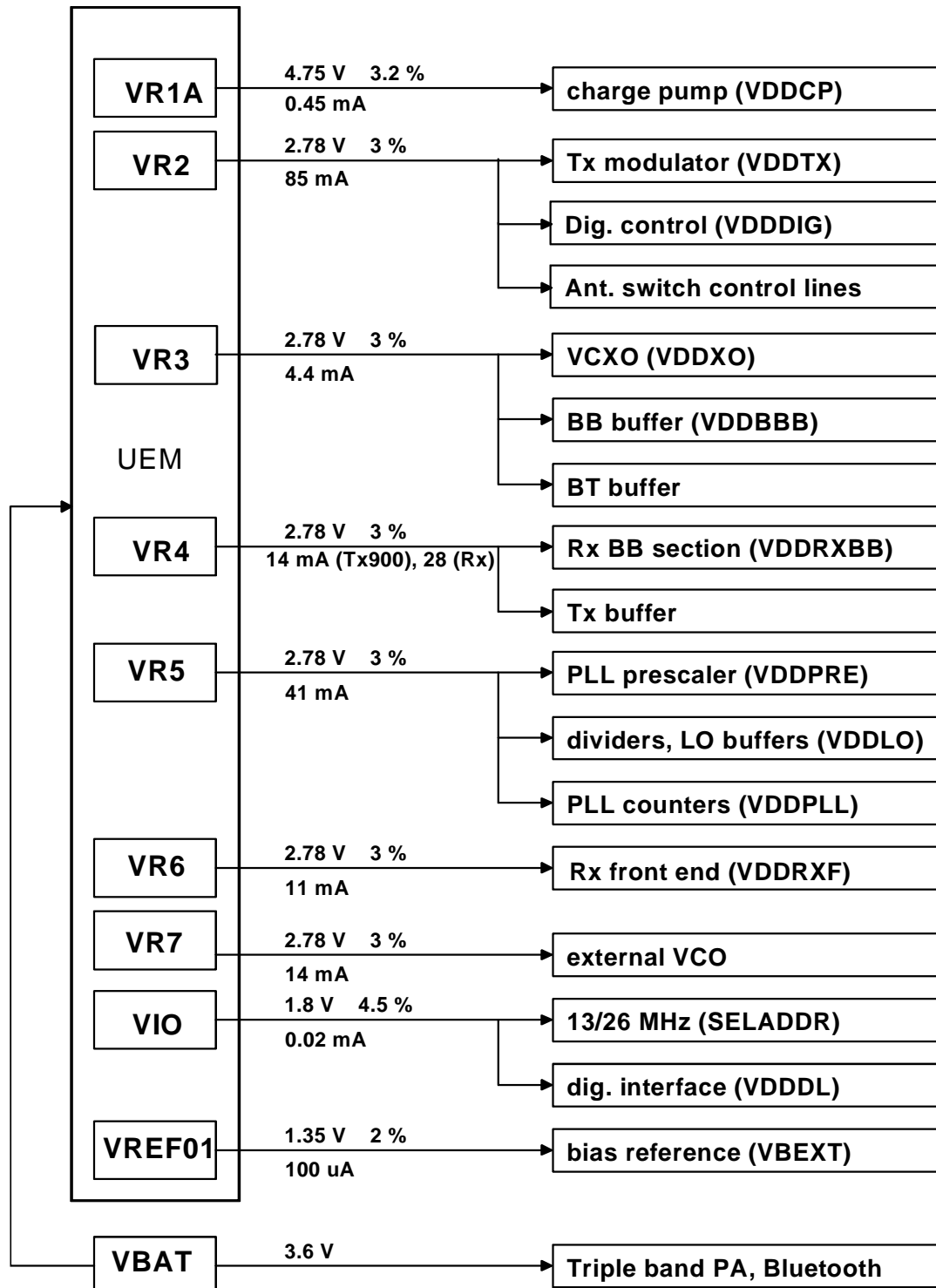

Figure 12: RF Power distribution diagram